



Document Reference AN060004H2

USING AN EXTERNAL POWER SOURCE FOR DIGITAL I/O's

WARNING: This equipment contains high voltages and rotating parts of motors and driven machines. Read the H2 instruction manual first and observe all safety precautions prior to working on this equipment!

Required Equipment:

H2 Inverter
H2 Vector
H2 Servo

Introduction:

All digital opto-isolated inputs and outputs are usually powered by an internal 24VDC power supply. This power supply is rated 200 mA. An EXTERNAL, customer supplied, power supply can be used in place of the internal power supply. An isolated DC power supply with tightly regulated 24VDC output voltage is recommended.

Procedure:

A. OPTO-ISOLATED INPUTS

1. The opto-isolated inputs (Terminals J2-8 to J2-16) are normally operated by closing contacts or switches between them and the input common, as shown in the instruction manuals for each type of H2 control. Factory connection of J2-8 (Enable) is made to J3-24 for internal "ACTIVE LOW" connection. Jumper JP5, located in the lower right hand corner of the control circuit board is in position 2 and 3 (DFT side).
 2. If an "ACTIVE HIGH" connection is desired with internal power supply, move jumper JP5 to position 2 and 3 of jumper JP6 (INP side), located just above the jumper JP5 location.
 3. If an EXTERNAL, customer supplied, 24VDC power supply is used, it will be necessary to again reposition jumper JP5/JP6. If "ACTIVE LOW" (Sinking) connection is used, place jumper JP5 in position 1 and 2 (EPN
-

side), and connect the power supply positive (+) and negative (-) terminals as shown in Fig 1. – Active Low Connections.

4. If an “ACTIVE HIGH” (Sourcing) connection is used with an EXTERNAL power supply, place jumper JP6 in position 1 and 2 (ENP side), and connect the power supply positive (+) and negative (-) terminals as shown in Fig. 1 – Active High Connections.

Note: Jumper JP5/JP6 described above is one jumper only and it is called JP5 or JP6 based on the location on the control board as shown in Fig. 1.

Fig. 1.

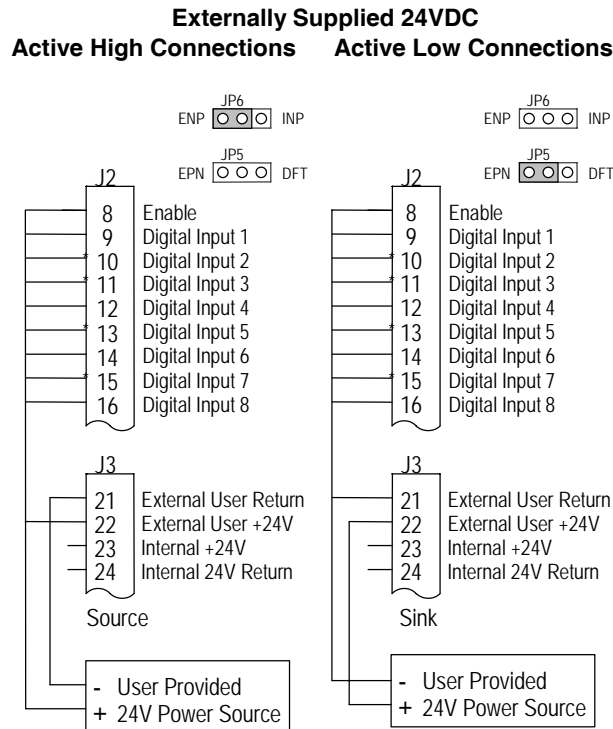

B. OPTO-ISOLATED OUTPUTS

1. Two programmable opto-isolated outputs are provided on terminals J2-17 to J2-20. These outputs can be used for external monitoring of various drive conditions. Each opto output is programmed in Level 1, OUTPUT SET-UP programming block. They are often powered from an internally supplied 24VDC. Opto outputs are rated 24VDC @ 60 mA resistive (non-inductive) load. The maximum voltage drop from digital output to common, when active, is 1.0VDC (TTL compatible).

- The two opto-isolated outputs can be used to switch an EXTERNAL 10-30VDC supply, and may be configured for either a sourcing or sinking mode. However, both must be configured the same. Power connections for sourcing and sinking modes with EXTERNALLY supplied 24VDC are shown in Fig. 2.

If the digital outputs are used to directly drive a DC relay coil, a flyback diode rated at 1 Amp, 100V (IN 4002 or equivalent) should be connected across the relay coil to reduce noise transmission as shown in Fig. 3.

Fig. 2.

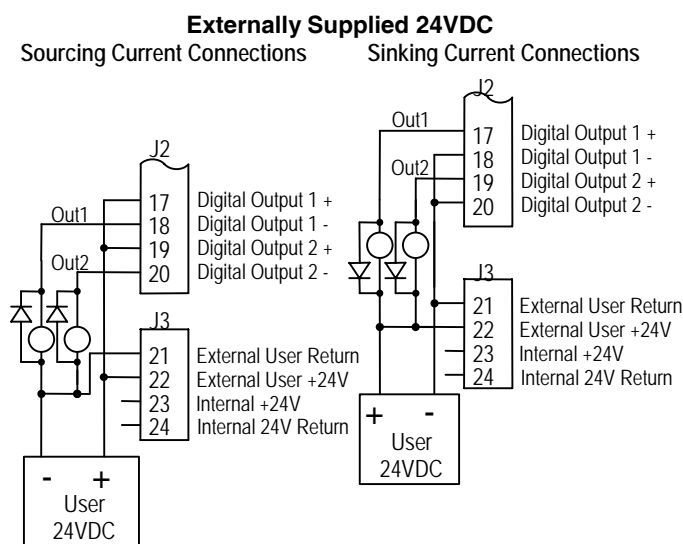

- Two programmable relay outputs are also provided. They are available as Form-C, Normally Open (N.O.) and Normally Closed (N.C.), voltage-free contacts on terminals J3-25 to J3-30. Relay outputs are rated 10-30VDC or 240VAC @ 5 Amp resistive (non-inductive) load.

If the relay outputs are used to directly drive an AC relay coil, install an RC snubber (0.47 uF capacitor in series with a 33 ohm resistor) across the coil to reduce noise transmission. For a DC relay coil use a flyback diode as described in item B-2 above.

The relay contacts and AC/DC coil noise suppression circuits are shown in Fig. 3.

Fig. 3.

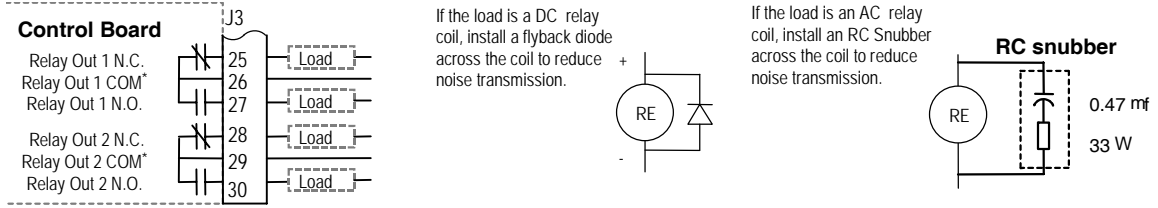

Opto-isolated input and output circuits are shown in Fig. 4.

Fig. 4.

