



Document Reference AN060002H2

Understanding H2 Digital Inputs

Required Equipment:

H2 Inverter
H2 Vector
H2 Servo

Introduction:

Series H2 drives offer enhanced digital inputs that are easily configured for internal or external power supply. Drive control board circuit logic is optically isolated from digital input voltage, thus providing a degree of protection from power surges and immunity from electromagnetic noise. Generally Baldor recommends using electromechanical contacts as digital inputs. Pushbuttons, selector switches, pressure switches, level switches, limit switches and PLC relay outputs are preferred digital input devices. However in those instances when TTL (transistor-to-transistor) attention must be made to the type of devices that provides input to Baldor H2 drive. DC input TTL logic must have proper +/- polarity, commonly referred as sinking or sourcing input configuration.

Digital inputs have the following characteristics:

- 10-30VDC rated voltage
- leakage current 10 μ A
- update 16msec

(note: In operating modes with 3 wire momentary digital inputs, a momentary input must be closed for minimum of 50 ms to assure it is recognized as valid.

Procedure:

Wiring diagrams Figures 1 through 4 illustrate typical digital input configuration. Observe +/- polarity when connecting TTL input devices. Connect both negative and positive of external power supply to drive terminal strip to ensure that external power supply voltage is being monitored by drive control circuitry.



Figure 1 below illustrates typical internal drive 24VDC power source connection for active low logic with input device sinking current from drive logic circuit.

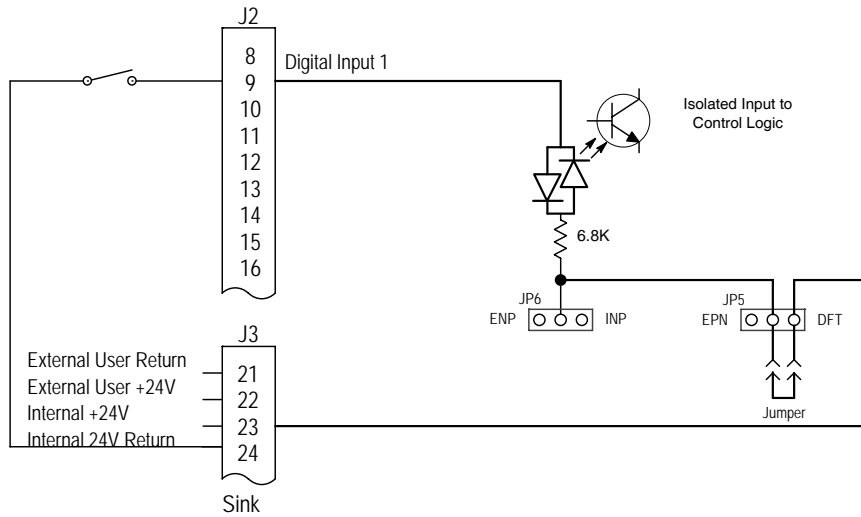

Figure 1

Figure 2 below illustrates typical internal drive 24VDC power source connection for active high logic with input device sourcing current from drive logic circuit.

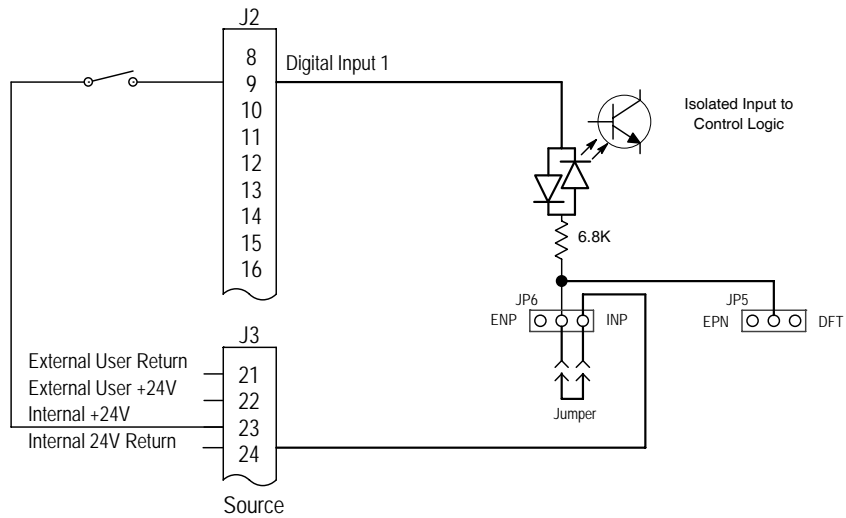

Figure 2

Figure 3 below illustrates typical external 24VDC power source connection for active low logic with input device sinking current from drive logic circuit.

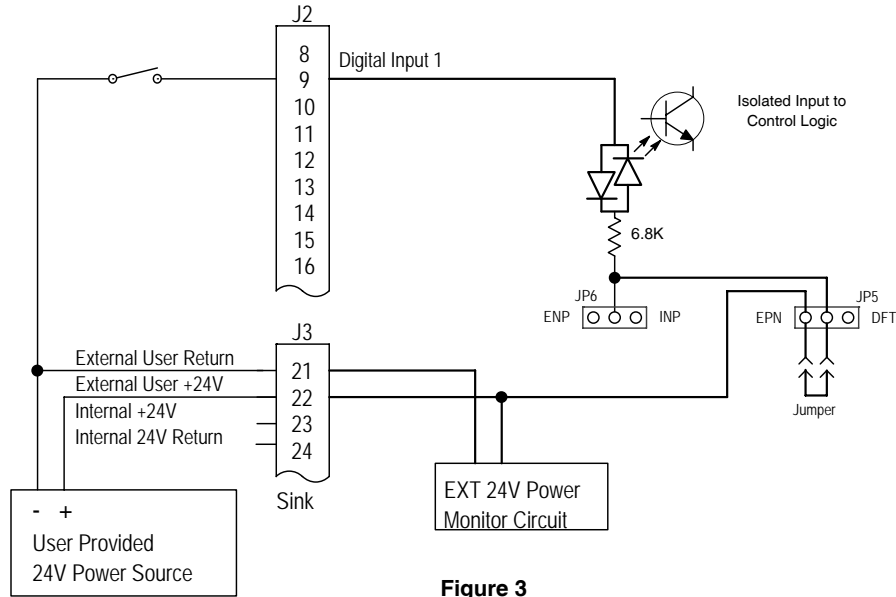

Figure 3

Figure 4 below illustrates typical external 24VDC power source connection for active high logic with input device sourcing current from drive logic circuit.

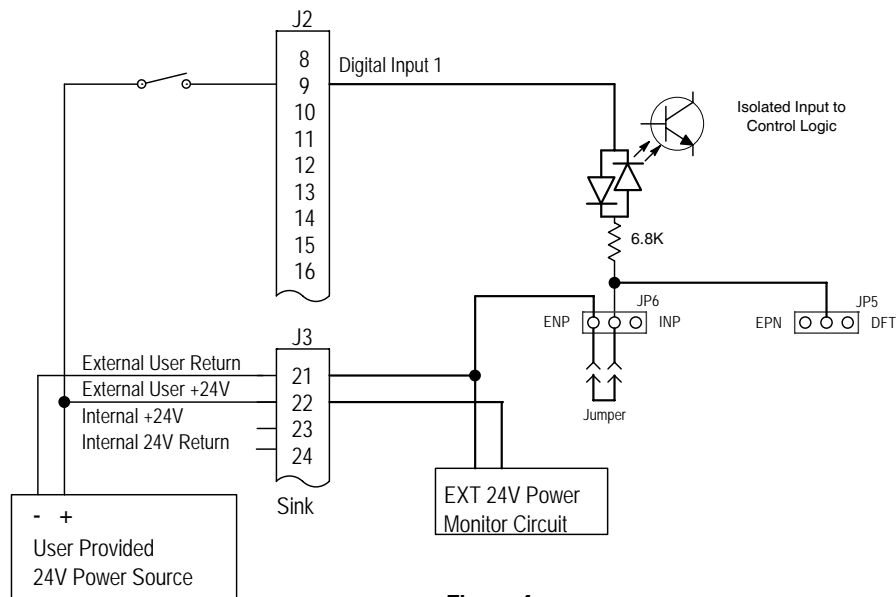

Figure 4