

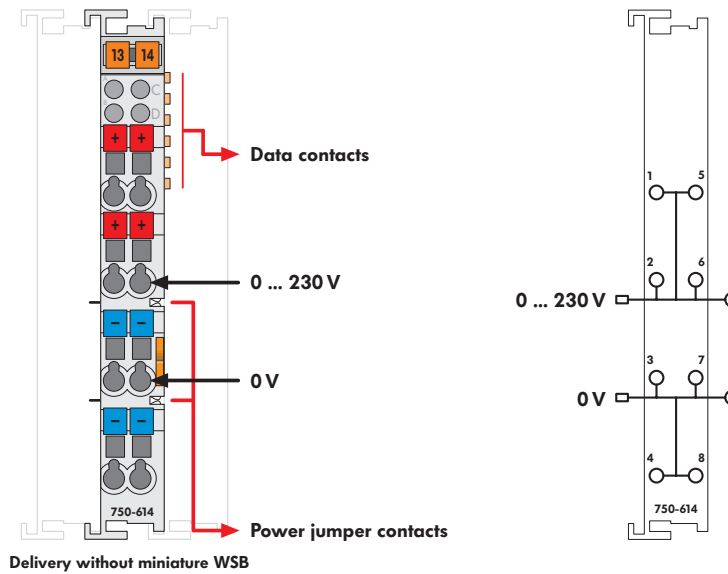

Field Side Connection Module

AC/DC 0 ... 230 V



This module allows additional + and - voltage connection points (up to 4 additional), eliminating external terminal blocks. Note: Ground (earth) or shield (screen) connection is discontinued at this point.

Description	Item-No.	Pack.-unit pcs	Technical Data
Field Side Connection	750-614	10 ¹⁾	Voltage via power jumper contacts s_{max} . AC/DC 0V ... 230V Current via power jumper contacts s_{max} . 10A
¹⁾ Also available individually			
General specifications			
Operating temperature	0°C ... +55°C		
Wire connection CAGE CLAMP®	0.08 mm ² ... 2.5 mm ² ; AWG 28 ... 14		
	8 ... 9 mm / 0.33 in stripped length		
Dimensions (mm) W x H x L	12 x 64* x 100		
	* from upper edge of 35 DIN rail		
Weight	ca 40 g		
Storage temperature	-25°C ... +85°C		
Relative air humidity	95% no condensation		
Vibration and shock resistance	acc. to IEC 60068-2-6 acc. to IEC 60068-2-27		
Degree of protection	IP 20		
EMC CE - Immunity to interference	acc. to EN 50082-2 (1996)		
EMC CE - Emission of interference	acc. to EN 50081-1 (1993)		
EMC marine applications - Immunity to interf.	acc. to Germanischer Lloyd (1997)		
EMC marine applications - Emission of interf.	acc. to Germanischer Lloyd (1997)		
Approvals			
UL and marine applications	see pages 1.10 ... 1.13		
CE	II 3 G EEx nA II T4, Class I Div2 ABCD T4A		
Conformity marking	CE		
Accessories			
	Item-No.	Pack.-unit pcs	
	Miniature WSB quick marking system		
	plain 248-501	5	
	with marking see pages 1.174 ... 1.175		